

# BERGMANN ALPHA-PACK-BIN APB 1120

WITH LOADING BUCKET.



**EXTREMELY  
FLEXIBLE.  
EXTREMELY  
EFFICIENT.  
EXTREMELY  
SAFE.**

**BERGMANN-ONLINE.COM**

**BERGMANN**  
Machines  
for Waste Management

# THE ORIGINAL.

## APB 1120

### FLEXIBLE.

Hydraulic tilting loading bucket for loose material, sweepings and waste that is difficult to lift – directly from ground level.

- › No ramp or step required
- › Ground-level loading (municipal vehicles, car trailers or similar)
- › Safe tipping: two-hand control, hydraulic drive
- › When retracted, the bucket fully closes the feed opening – no additional cover required

### EFFICIENT.

Linear compaction system with 100% power transfer in the APB.

- › Up to 75% lower disposal costs through fewer collections
- › Maintenance-friendly thanks to a pull-out hydraulic power unit



**GROUND LEVEL.** Loading without a ramp – loose material can be transferred easily.



**EMPTIES COMPLETELY.** Convenient operation of the tipping function via the control panel – no material falls outside.



**COVER FUNCTION.** In transport position, the feed opening is fully closed.

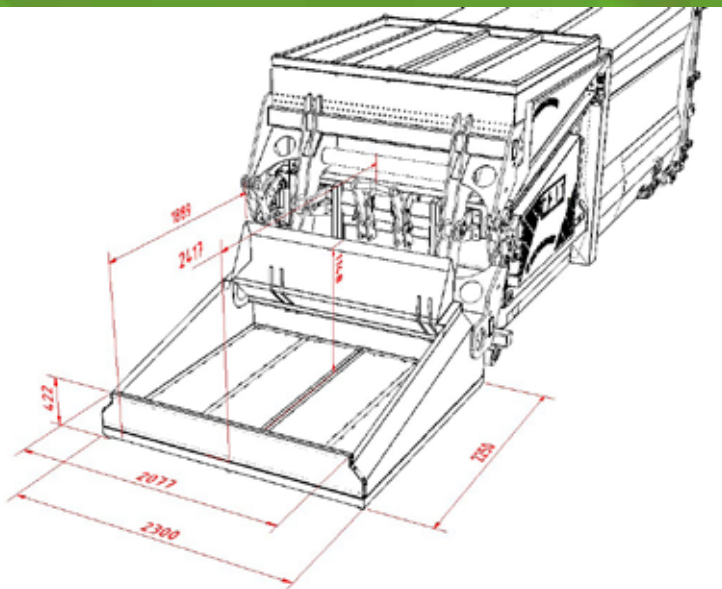

**Heinz Bergmann OHG**

Von-Arenberg-Straße 7 | 49762 Lathen | Germany

T +49 (0) 5933 955-0 | [info@bergmann-online.com](mailto:info@bergmann-online.com)

**BERGMANN-ONLINE.COM**

#### DESCRIPTION

Mobile press container with BERGMANN linear compaction system and integrated loading bucket.

#### APPLICATIONS

Municipal services | recycling centres

#### WASTE TYPES

Loose, free-flowing or difficult-to-lift waste/materials

#### TECHNICAL DATA

##### PAYLOAD

approx. 900 kg

##### WEIGHT

approx. 1,240 kg

##### DIMENSIONS

2,300 mm × 2,250 mm × 1,150 mm

##### TECHNICAL VOLUME

approx. 2.6 m<sup>3</sup>

Technical specifications subject to change.